



EARTHSTONE

WOOD-FIRE OVENS

INSTALLATION, OPERATION AND MAINTENANCE INSTRUCTIONS FOR GAS FIRED OVEN

THE DESIGN, MANUFACTURE AND INSTALLATION OF THE EARTHSTONE GAS FIRED OVENS IS THE SAME AS THE EARTHSTONE MODEL-PA WOOD FIRE OVENS. THE VENTING SYSTEM GUIDELINES ARE FOR SOLID FUEL APPLIANCES EVEN THOUGH THIS UNIT IS FUELED BY GAS. A SMALL AMOUNT OF WOOD CAN BE BURNED ON THE OPPOSITE SIDE OF THE GAS BURNER TO ADD FLAVOR AND AESTHETIC VALUE IF DESIRED.

INSTRUCTIONS TO PURCHASER

CONTACT LOCAL GAS SUPPLIER TO OBTAIN INFORMATION REGARDING INSTRUCTIONS TO BE FOLLOWED IN EVENT USER SMELLS GAS. POST THESE INSTRUCTIONS IN A PROMINENT LOCATION.

FOR YOUR SAFETY

DO NOT STORE OR USE GASOLINE OR OTHER FLAMMABLE LIQUIDS OR VAPORS IN THE VICINITY OF THIS OR ANY OTHER APPLIANCE.

WARNING

IMPROPER INSTALLATION, ADJUSTMENT, ALTERATION, SERVICE OR MAINTENANCE CAN CAUSE PROPERTY DAMAGE, INJURY OR DEATH. READ THE INSTALLATION, OPERATION AND MAINTENANCE INSTRUCTIONS THOROUGHLY BEFORE INSTALLATION OR SERVICING THIS EQUIPMENT.

A CAUSE OF OVEN RELATED FIRES IS FAILURE TO MAINTAIN REQUIRED CLEARANCES (AIR SPACES) TO COMBUSTIBLE MATERIALS. IT IS OF UTMOST IMPORTANCE THAT THIS OVEN BE INSTALLED ONLY IN ACCORDANCE WITH THESE INSTRUCTIONS.

RETAIN THIS MANUAL FOR FUTURE REFERENCE.

**OVEN DOOR MUST BE REMOVED
BEFORE FIRING AND OPERATING OVEN.**



Intertek



Intertek

EARTHSTONE OVENS – 6717 SAN FERNANDO RD, GLENDALE CA 91201

TEL: 800-840-4915 - 818-553-1134

FAX: 818-553-1133

IMPORTANT INFORMATION

MINIMUM CLEARANCES TO COMBUSTIBLE AND NON COMBUSTIBLE CONSTRUCTION.

COMBUSTIBLES:	SIDES 1”	BACK 1”	
NON COMBUSTIBLES	SIDES 0”	BACK 0”	

ADEQUATE CLEARANCE MUST BE PROVIDED FOR AIR OPENINGS INTO THE COMBUSTION CHAMBER, FOR SERVICING AND PROPER OPERATION (PAG AND PAGW MODELS ONLY). A MINIMUM OPENING OF 24” X 24” MUST BE LOCATED ON THE BOTTOM HALF OF THE OVEN. THIS WILL ALLOW FOR PROPER COMBUSTION AIR INTO THE BURNER HOUSING. NOT HAVING PROPER COMBUSTION AIR WILL CAUSE IMPROPER OPERATION AND MAY CAUSE DAMAGE TO THE BURNER SYSTEM. INSTALLING A SEALED ENCLOSURE AROUND THE OVEN SHELL MAY ALSO CAUSE IMPROPER OPERATION BY STARVING THE BURNER SYSTEM OF COMBUSTION AIR. THE USE OF RETURN AIR SYSTEMS OR OTHER VENTING SYSTEMS LOCATED WITHIN SEALED ENCLOSURES WHICH SURROUND THE OVEN MAY CAUSE NEGATIVE PRESSURE AND IN TURN AFFECT THE OPERATION OF THE OVEN. *SEE PAGES 14 AND 15 FOR MORE INFORMATION FOR MORE INFORMATION PLEASE CALL: 800-840-4915 OR 818-553-1134**

KEEP APPLIANCE FREE AND CLEAR FROM COMBUSTIBLES.

DO NOT OBSTRUCT THE FLOW OF COMBUSTION AND VENTILATION AIR TO THE APPLIANCE.

ELECTRICAL DIAGRAM IS LOCATED ON THE CONTROL BOX.

INSTALLATION MUST CONFORM WITH LOCAL CODES, OR IN THE ABSENCE OF LOCAL CODES, WITH THE NATIONAL FUEL GAS CODE ANSI Z223.1, THE NATURAL GAS INSTALLATION CODE CAN/CGA-B149.1 OR THE PROPANE INSTALLATION CODE CAN/CGA-149.2, AS APPLICABLE, INCLUDING:

- 1 THE APPLIANCE AND ITS INDIVIDUAL SHUT OFF VALVE MUST BE DISCONNECTED FROM THE GAS SUPPLY PIPING SYSTEM DURING ANY PRESSURE TESTING OF THAT SYSTEM AT TEST PRESSURES IN EXCESS OF ½ PSI (3.45 Kpa).
- 2 THE APPLIANCE MUST BE ISOLATED FROM THE GAS SUPPLY PIPING SYSTEM BY CLOSING ITS INDIVIDUAL MANUAL SHUTOFF VALVE DURING ANY PRESSURE TESTING OF THE GAS SUPPLY PIPING SYSTEM AT THE TEST PRESSURES EQUAL TO OR LESS THAN ½ PSI (3.45 Kpa).

THIS APPLIANCE, WHEN INSTALLED, MUST BE ELECTRICALLY GROUNDED IN ACCORDANCE WITH LOCAL CODES, OR IN THE ABSENCE OF LOCAL CODES, WITH THE NATIONAL ELECTRICAL CODE, ANSI/NFPA 70 OR THE CANADIAN ELECTRICAL CODE, CSA C22.1, AS APPLICABLE.

ELECTRICAL AND GAS REQUIREMENTS:

- 1 120VAC – 2.5 AMP OUTLET
- ¾ INCH GAS OUTLET (Fitting for supplied flex hose 5/8 in. O.D. Flare 15/16-16 Thread)
- GAS INLET PRESSURE TO OVEN: 7” W.C. FOR NATURAL, 12” W.C. FOR LP GAS
- GAS REGULATING VALVE (I.E. MAXITROL RV 53, 3-6) AND SHUTOFF VALVE BY OTHERS**

MANIFOLD GAS PRESSURE – FACTORY SETTINGS

160-PAG(W) 4.5” W.C. - .170,000 BTU	130-PAG(W) 5.0” W.C. - 140,000 BTU
120-PAG(W) 3.5” W.C. - 130,000 BTU	110-PAG(W) 5.0” W.C. - 110,000 BTU
90-PAG(W) 4.0 “ W.C. - 85,000 BTU	
For LP Gas see page 17	

GAS INSTALLATION

THE OVEN SHOULD BE CONNECTED ONLY TO THE TYPE OF GAS FOR WHICH IT IS EQUIPPED.

ALL PIPES AND JOINTS MUST BE TESTED FOR LEAKS WITH A SOAP AND WATER SOLUTION BEFORE OPERATING THE OVEN. DO NOT USE AN OPEN FLAME TO CHECK FOR LEAKS.

A 1/8 PRESSURE TAP IS LOCATED ON THE COMBUSTION GAS CONTROL TO CHECK THE MANIFOLD PRESSURE. REFER TO NAMEPLATE FOR PROPER SETTING. THE CONTROL IS PRESET AT THE FACTORY PRIOR TO SHIPPING.

CONNECT GAS SUPPLY (3/4 INCH) TO OVEN. USE PIPE JOINT COMPOUND THAT IS NON REACTIVE TO LP GAS ON ALL THREADED JOINTS. CHECK FOR GAS LEAKS WITH SOAPY WATER SOLUTION.

NOTE: IT IS RECOMMENDED THAT A SERVICE SHUTOFF VALVE BE PROVIDED OUTSIDE THE OVEN AT THE TIME OF INSTALLATION

CONNECT OVEN TO A 120 VAC, 60HZ, 2.5 AMP 1 PH POWER SUPPLY. MAKE SURE THAT SYSTEM IS PROPERLY GROUNDED.

OPERATION

READ ALL INSTRUCTIONS CAREFULLY. IMPROPER USE OF THIS APPLIANCE MAY RESULT IN A BUILDING FIRE OR PERSONAL INJURY. INSTRUCTIONS MUST BE READ AND THOROUGHLY UNDERSTOOD BY ALL OPERATING AND SUPERVISING PERSONNEL. WATCH TRAINING VIDEO FOR VISUAL OPERATION INSTRUCTIONS.

THIS OVEN IS INTENDED FOR ATTENDED OPERATION BY TRAINED AND QUALIFIED PERSONNEL ONLY.

THIS OVEN IS A HEAT PRODUCING APPLIANCE AND MAY CAUSE SEVERE BURNS IF TOUCHED.

THIS UNIT IS DESIGNED AS A GAS-FIRED OR GAS/WOOD FIRED OVEN. DIRECT FOOD CONTACT WITH HEARTH IS RESTRICTED TO PIZZAS AND BREAD PRODUCTS ONLY. FOR OTHER FOODS REFER TO MANUFACTURE OPERATION GUIDELINES.

OVEN DOOR MUST BE REMOVED BEFORE OPERATING OVEN.

FIRING OVEN

BEFORE STARTING, TURN ON EXHAUST AND MAKE-UP AIR BLOWERS.

TURN ON SERVICE SHUT-OFF VALVE.

TURN ON KNOB OF COMBINATION GAS CONTROL.

SET THERMOSTAT TO DESIRED TEMPERATURE SETTING (600 TO 750)

TURN ON ELECTRICAL SWITCH. A SPARK IS GENERATED WHICH WILL IGNITE THE GAS AT THE MAIN BURNER.

SHUTTING DOWN OVEN.

FOR TEMPORARY SHUT DOWN TURN OFF ELECTRICAL SWITCH.

FOR COMPLETE SHUT DOWN TURN KNOB OF COMBUSTION GAS CONTROL TO OFF.

WOOD AND/OR GAS FIRED COMBINATION PIZZA OVEN OPERATING INSTRUCTIONS

WARNING:

READ ALL INSTRUCTIONS CAREFULLY. IMPROPER USE OF THIS APPLIANCE MAY RESULT IN A BUILDING FIRE OR PERSONAL INJURY. INSTRUCTIONS MUST BE READ AND THOROUGHLY UNDERSTOOD BY ALL OPERATING AND SUPERVISING PERSONNEL. WATCH TRAINING VIDEO FOR VISUAL OPERATION INSTRUCTIONS.

THIS OVEN IS INTENDED FOR ATTENDED OPERATION BY TRAINED AND QUALIFIED PERSONNEL ONLY.

THIS OVEN IS A HEAT PRODUCING APPLIANCE AND MAY CAUSE SEVERE BURNS IF TOUCHED.

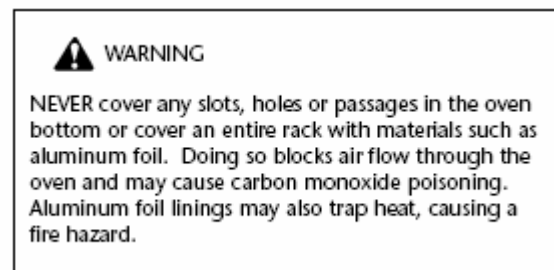
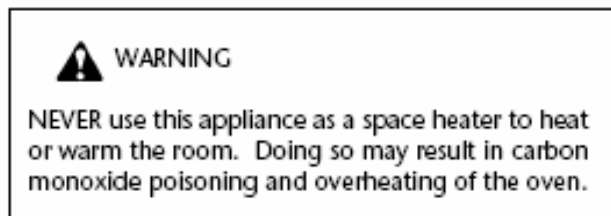

DO NOT OVER FIRE. IF FLAME SPILLS FROM THE DOOR OPENING OR OVEN TEMPERATURE EXCEEDS 1000 DEGREES FAHRENHEIT, YOU ARE OVER FIRING.

THIS UNIT IS DESIGNED AS A GAS OR GAS/WOOD FIRED OVEN. DIRECT FOOD CONTACT WITH THE HEARTH IS RESTRICTED TO PIZZAS AND BREAD PRODUCTS ONLY. FOR OTHER FOODS REFER TO MANUFACTURE OPERATION GUIDELINES. **ALL WOOD EMBERS BURNED INSIDE THE OVEN MUST BE PLACED DIRECTLY ON THE OPPOSITE SIDE OF THE GAS BURNER (SEE DIAGRAM). WOOD SHOULD BE USED ONLY FOR FLAVORING AND AESTHETIC VALUE, THE MAIN SOURCE OF HEAT SHOULD BE SUPPLIED BY THE GAS BURNER**

KEEP A PROPER FIRE EXTINGUISHER CLOSE TO THE OVEN AT ALL TIMES. EXTINGUISHER MUST BE RATED FOR USE ON WOOD FIRES. INSTRUCT ALL PERSONNEL ABOUT LOCATION AND USE OF THE FIRE EXTINGUISHER AND PROPER FIRE EMERGENCY PROCEDURES.

- a- Before starting, turn "ON" exhaust fan and make-up air blowers.
- b- Place a small amount of wood and kindling on the hearth over a fire-starter block. Light fire-starter. At any time do not use more than four pieces of wood,
- c- CAUTION: NEVER USE GASOLINE TYPE LANTERN FUEL, KEROSENE, CHARCOAL LIGHTER FLUID OR SIMILAR PRODUCTS TO START OR "FRESHEN UP" A FIRE IN THIS OVEN. KEEP ALL SUCH LIQUIDS WELL AWAY FROM THE OVEN WHEN IN USE.
- d. When the kindling is burning well, add larger pieces of firewood. USE WELL-SEASONED OR DRIED WOOD ONLY.
- e- Continue to add fuel as needed to maintain the desired heated rate, being careful to never over fire the unit.
- f- Whenever fuel is added, the fire may be poked and stirred with a wood handling tool. This will allow air to move through the fuel bed for proper combustion.

- g- When oven is heated to cooking temperature, move wood and ash to the opposite side of the gas burner clear the hearth for cooking product. Insert ash barrier in front of burning wood. This is to separate the cooking area from the ash and wood. Clean cooking area as described in the DISPOSAL OF ASHES section before commencing cooking procedures. Food must be placed on an appropriate cooking pan before being set into the oven.

DOOR SHOULD BE CLOSED ONLY AFTER GAS BURNER IS TURNED OFF.

1. The first two fires should be small in order to properly cure the masonry in the unit. One fire each day for one hour, for a total of six days. **DO NOT USE PRODUCTS NOT SPECIFIED FOR USE WITH THIS OVEN.** Maintain a minimum clearance of 36 inches in front of oven to combustible materials.
2. In case of out of control fire **shut gas off and** close door tightly.

CAUTION--AVOID POSSIBLE HAZARDOUS FLARE-UPS AND SMOKE SPILLAGE. WHEN REMOVING DOOR FROM IN FRONT OF DOOR OPENING, SLIDE DOOR OUT 2-3 INCHES FROM OPENING AND THEN WAIT 15 SECONDS BEFORE REMOVING DOOR COMPLETELY. FLARE-UPS CAN OCCUR WHEN DOOR IS OPENED SUDDENLY. KEEP FACE AND HANDS AWAY FROM DOOR OPENING.

3. Burn only seasoned or dried untreated solid wood fuel in the oven. **DO NOT BURN OTHER FUELS IN THE OVEN. DO NOT BURN CHARCOALS, COALS, TRASH/GARBAGE OR MANUFACTURED LOGS (PROCESSED SOLID FUEL).**
4. Firewood stored in the vicinity of the oven must be kept in a tightly-closed metal container; see maintenance Instructions and NFPA 96. Keep firewood container closed at all times when not adding or removing firewood. Keep container a considerable distance from the oven and far away from sources of heat or ignition. **DO NOT** store matches, paper or other easily ignited items with firewood.
5. Provisions must be made to supply sufficient combustion air into the structure when using this appliance. Combustion air must be supplied in accordance with local codes and the Uniform Mechanical Code and NFPA 96. Exhaust hood and make-up air blowers must be "ON" at all times during firing of the oven. If the exhaust hood power ventilator fails, close oven door to extinguish the fire and prevent temperature buildup in the hood duct which can activate the emergency fire suppression system.
6. Use only non-combustible hearth tools and cooking implements inside the oven. Store implements well away from all combustible materials in a proper fixture which will capture any ashes or hot coals which may be carried out of the oven on the implements.
7. The fire should be built directly on the hearth; **DO NOT** elevate fire.

WOOD FIRE MAINTENANCE INSTRUCTIONS

WARNING:

READ ALL INSTRUCTIONS CAREFULLY. IMPROPER USE OR MAINTENANCE OF THIS APPLIANCE MAY RESULT IN A BUILDING FIRE OR PERSONAL INJURY.

1. Always keep area around the unit clean and clear of all combustible materials. Keep all furnishings, fuel and other combustible objects a considerable distance away from the oven hearth.
2. **DISPOSAL OF ASHES**—Ashes from Ash Pan should be placed in a metal container with a tight-fitting lid. The closed container should be placed on a non-combustible floor or on the ground, well away from all combustible materials, pending final disposal. If the ashes are disposed by the burial in soil or otherwise locally dispersed, they

should be retained in the closed container until all cinders have thoroughly cooled. After ashes have been removed mop down hearth with clean damp cloths.

3. Store wood in a cool, dry place well away from any source of flame or heat. If stored outside, keep the fuel covered to protect from rain or snow. If stored inside, fuel should be kept in a covered metal container at least 6 inches

above the floor. Keep paper, rags and other easily ignited materials away from wood fuel. Refer to NFPA 96 for wood storage procedures.

4. At least at the end of each shift the area around the unit must be thoroughly cleaned of all wood, wood shavings, embers, ashes and other refuse. All mats (if present, mats must be non-combustible) must be picked up and carefully swept along with the floor during this clean up. After clean up around the unit, brooms should be thoroughly wet down to extinguish hot coals, then stored well away from combustible materials.

5. **Creosote - Formation and need for removal**

WHEN WOOD IS BURNED SLOWLY, IT PRODUCES TAR AND OTHER ORGANIC VAPORS, WHICH COMBINE WITH EXPELLED MOISTURE TO FORM CREOSOTE. THE CREOSOTE VAPORS CONDENSE IN THE RELATIVELY COOL OVEN FLUE AND EXHAUST HOOD OF DUCT, PARTICULARLY A SLOW

burning fire. As a result, creosote residue accumulates on the flue lining and exhaust hood. When ignited, this creosote makes an extremely hot fire.

The oven flue, exhaust duct and power ventilator should be inspected at least twice monthly during normal use to determine if creosote buildup has occurred. If creosote and/or grease has accumulated, it should be removed to reduce the risk of fire. Experienced chimney and duct servicing personnel who are qualified in the removal of both creosote and grease from flues and ducts should be contracted to do the inspection and cleaning. The inspection and cleaning schedule must be adjusted as needed to prevent the buildup of creosote and/or grease. More frequent inspections and cleanings are indicated when excessive buildup occurs between regular inspections. The rate of accumulation can increase whenever 1) there is a change in the use of the oven 2) when the type or moisture content of the firewood changes 3) when other variables change.

The oven, exhaust hood and grease filters should be cleaned on a daily basis. The Grease filters can be removed and cleaned in a dishwasher or sink. Refer to the NFPA 96 requirements and the Exhaust Hood or Grease Duct manufacturer's instructions for inspection, maintenance and cleaning of the venting system.

DO NOT CLEAN UNIT, HOOD OR VENT WHILE HOT OR WHILE OVEN IS BEING FIRED.

6. The entire unit and vent system should be inspected frequently for proper fit, operation and soundness of parts. If any malfunctioning parts, leakage, deterioration, or other problems are noted, contact your dealer to inspect and repair the unit, or qualified ventilation repair service to inspect and repair the vent system. DO NOT OPERATE THE UNIT IF INSTALLED OR FUNCTIONING IMPROPERLY.
7. All maintenance must be performed by qualified personnel.
8. Refer to NFPA 96 for procedures for inspection, cleaning and maintenance for solid fuel cooking.
9. **SERVICE OF OVEN TEMP. MONITORING EQUIPMENT**
 - A) **Replace with Temp. gauge rated 6-14 VDC, Temp. range -58⁰F to 932⁰F. (AJ Antunes – TTC)**
 - B) **Replace AC adapter with U.L. listed plug-in class 2 transformer rated input 120 VAC, 60 HZ, 9 Watts, output 12 VDC, 200 Ma.**
 - C) **Replace Thermocouple with a metal sheathed Type-"K" thermocouple, Min. 6 ft.**
10. Save these instructions for future reference.

GAS BURNER MAINTENANCE

WARNING:

IMPROPER MAINTENANCE OF THIS APPLIANCE MAY RESULT IN A BUILDING FIRE OR PERSONAL INJURY.

DO NOT CLEAN OR SERVICE OVEN, HOOD OR VENT WHILE HOT OR WHILE OVEN IS IN OPERATION.

CONTACT THE FACTORY OR FACTORY REPRESENTATIVE OR A LOCAL SERVICE COMPANY TO PERFORM MAINTENANCE AND REPAIRS.

1. CLEAN OVEN REGULARLY WITH RECOMMENDATION CLEANING AGENTS AS NECESSARY.
2. DISCONNECT POWER SUPPLY TO THE OVEN BEFORE CLEANING OR SERVICING.

3. TO REMOVE BURNER FOR CLEANING FOLLOW THESE STEPS:

DISCONNECT CABLE FROM SPARK IGNITER.

UNSCREW FITTING OF GAS SUPPLY LINE WHICH IS NEAREST TO BURNER ASSEMBLY THIS SUPPLY LINE CONNECTS THE GAS VALVE TO BURNER ASSEMBLY.

TILT OPPOSITE END OF BURNER UP AND SLIDE BURNER DOWN FROM BURNER ENCLOSURE.

CLEAN BURNER WITH WIRE BRUSH TO ENSURE THAT ALL THE JET HOLES ARE CLEAN.

4. TO REPLACE BURNER AFTER CLEANING FOLLOW THESE STEPS:

SLIDE BURNER INTO ENCLOSURE BY INSERTING END OPPOSITE TO GAS CONNECTION FIRST THEN THE REMAINING OF THE BURNER UNTIL BURNER RESTS HORIZONTALLY IN BURNER ENCLOSURE.

CONNECT GAS SUPPLY LINE TO BURNER.

CONNECT CABLE TO SPARK IGNITER.

**NOTE: ALWAYS CHECK FOR GAS LEAKS USING A SOAPY SOLUTION.
NEVER USE OPEN FLAME TO CHECK FOR GAS LEAKS**

GAS BURNER CONTROLS

CONTROL BOX

- 1 ON/OFF**—MAIN SWITCH TO TURN BURNER ON AND OFF
- 2 HI/OFF**---BURNER WILL REMAIN ON HIGH FLAME UNTIL DESIRED TEMPERATURE IS REACHED. ONCE DESIRED TEMPERATURE IS REACHED BURNER WILL SHUT OFF. WHEN TEMPERATURE FALLS BELOW DESIRED TEMPERATURE HI FLAME WILL COME BACK ON.
- 3 HI/LO**--- BURNER WILL REMAIN ON HIGH FLAME UNTIL DESIRED TEMPERATURE IS REACHED. ONCE DESIRED TEMPERATURE IS REACHED BURNER WILL GO TO LOW FLAME. WHEN TEMPERATURE FALLS BELOW DESIRED TEMPERATURE HI FLAME WILL COME BACK ON.

TEMPERATURE READOUT CONTROLS

- 4 BLACK DIAL KNOB**—ROTATE CLOCKWISE TO RAISE OR COUNTER-CLOCKWISE TO LOWER SET TEMPERATURE.
- 5 RED BUTTON**—USED SIMULTANEOUSLY WITH BLACK DIAL KNOB TO SET TEMPERATURE. PUSH AND HOLD, SET TEMPERATURE IS DISPLAYED. WHEN RELEASED ACTUAL TEMPERATURE IS DISPLAYED.

SEE PAGE LABELED SWITCH DIAGRAM LAYOUT

OPERATION

FIRING OVEN (NOTE: DO NOT CLOSE DOOR WHILE OVEN IS BEING FIRED)

MAKE SURE GAS CONTROL VALVE IS IN THE ON POSITION.

WHILE PRESSING RED BUTTON, TURN BLACK KNOB TO DESIRED TEMPERATURE. THIS SHOULD BE ABOUT 650 F TO 750 F.

MOVE SWITCH TO HI/LOW POSITION.

TURN MAIN POWER SWITCH TO ON. A SPARK IS GENERATED WHICH WILL IGNITE THE GAS AT THE MAIN BURNER INSIDE THE OVEN.

DAILY THERMAL CLEANING PROCEDURES:

- INCREASE OVEN TEMPERATURE TO 850 DEGREES

- LEAVE OVEN DOOR SLIGHTLY OPEN, AT LEAST THREE INCHES. THIS IS DONE BY ROTATING OVEN DOOR AT A 45-DEGREE ANGLE. OVEN DOOR SHOULD NEVER BE CLOSED WHEN BURNER IS ON. OVEN INTERIOR WILL TURN BLACK IF DOOR IS CLOSED WHILE BURNER IS ON. A BACK FLASH CAN ALSO OCCUR.



- AFTER TWO HOURS TURN OVEN OFF AND CLOSE OVEN DOOR.
- DO NOT USE ANY CLEANING AGENTS IN THE OVEN

SHUTTING DOWN OVEN

TURN MAIN POWER SWITCH TO OFF POSITION.

IF OVEN IS BEING SHUT DOWN FOR THE NIGHT, GAS CONTROL VALVE SHOULD BE TURNED TO OFF POSITION.

SAVE THESE INSTRUCTIONS.

IF YOU HAVE ANY QUESTIONS PLEASE CALL 800-840-4915 or 818-553-1134

GAS BURNER CONTROLS



CLEARANCE INFORMATION FOR FACADES

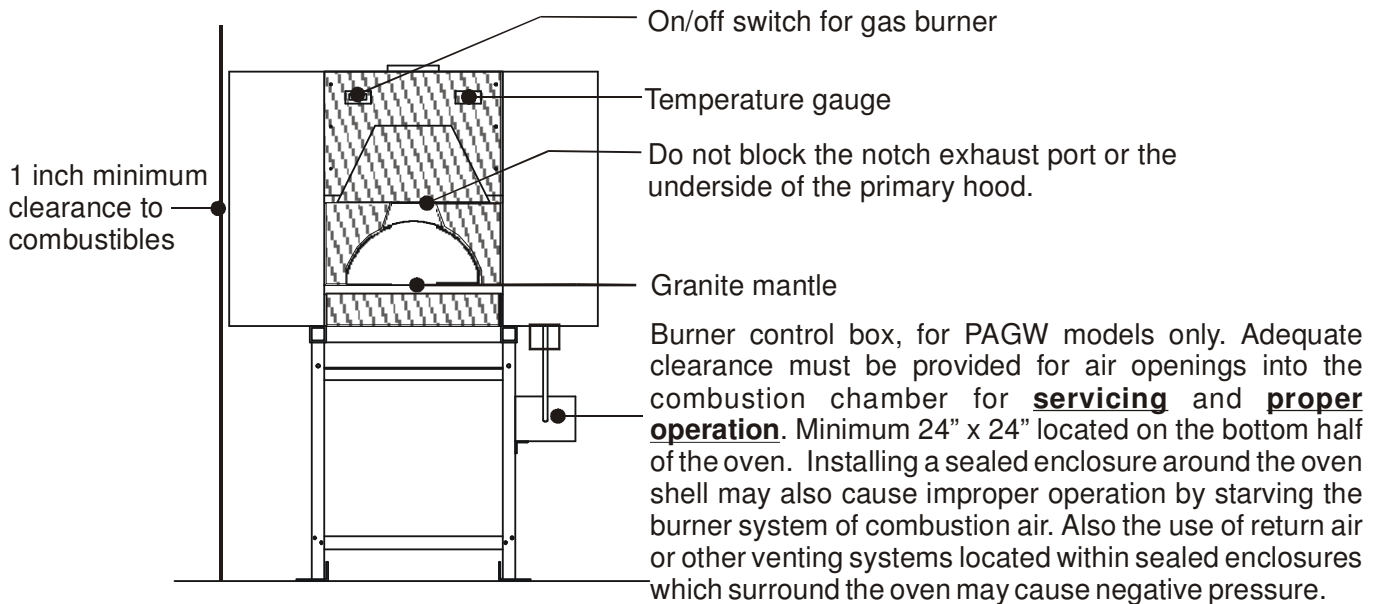
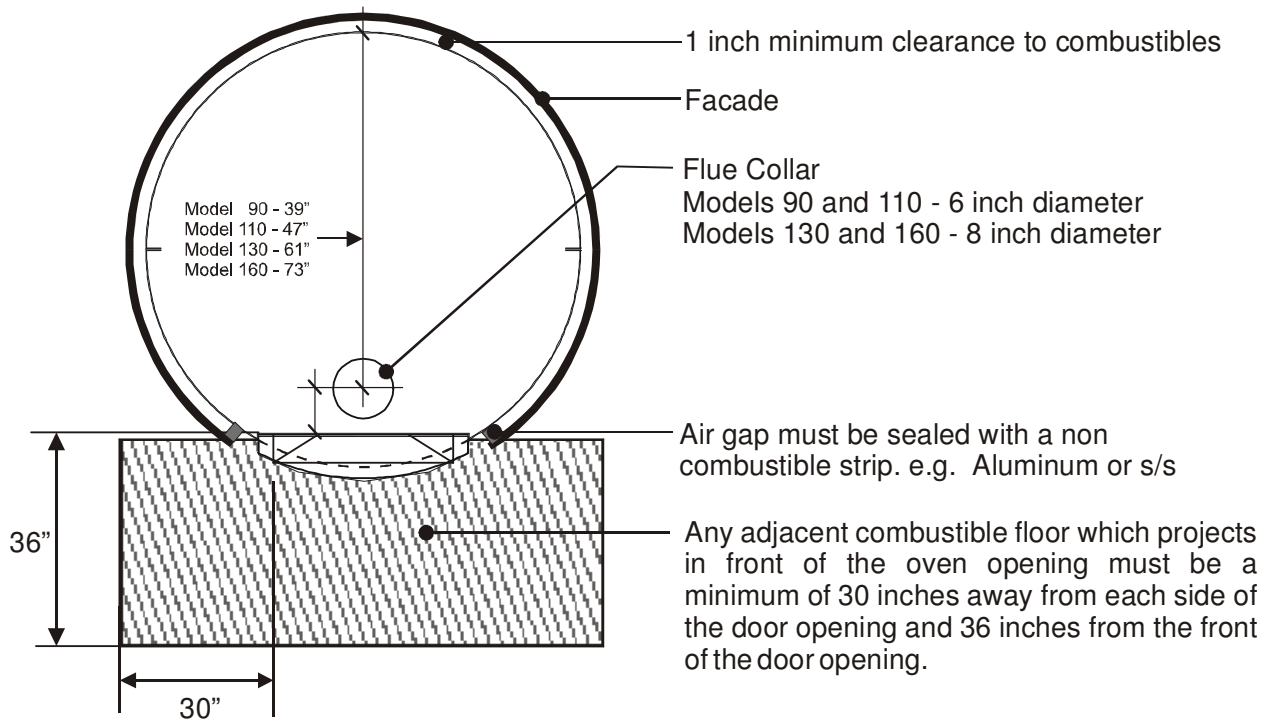

 If this area is to be covered with a facade it must be of a non-combustible material. Temperature gauge and On/off switch can be extended to attach over facade.

EARTHSTONE

WOOD-FIRE OVENS

All wood fired in a gas/wood combination oven should be located on the opposite side of the gas burner. Take caution to avoid ashes from entering the gas burner cavity.

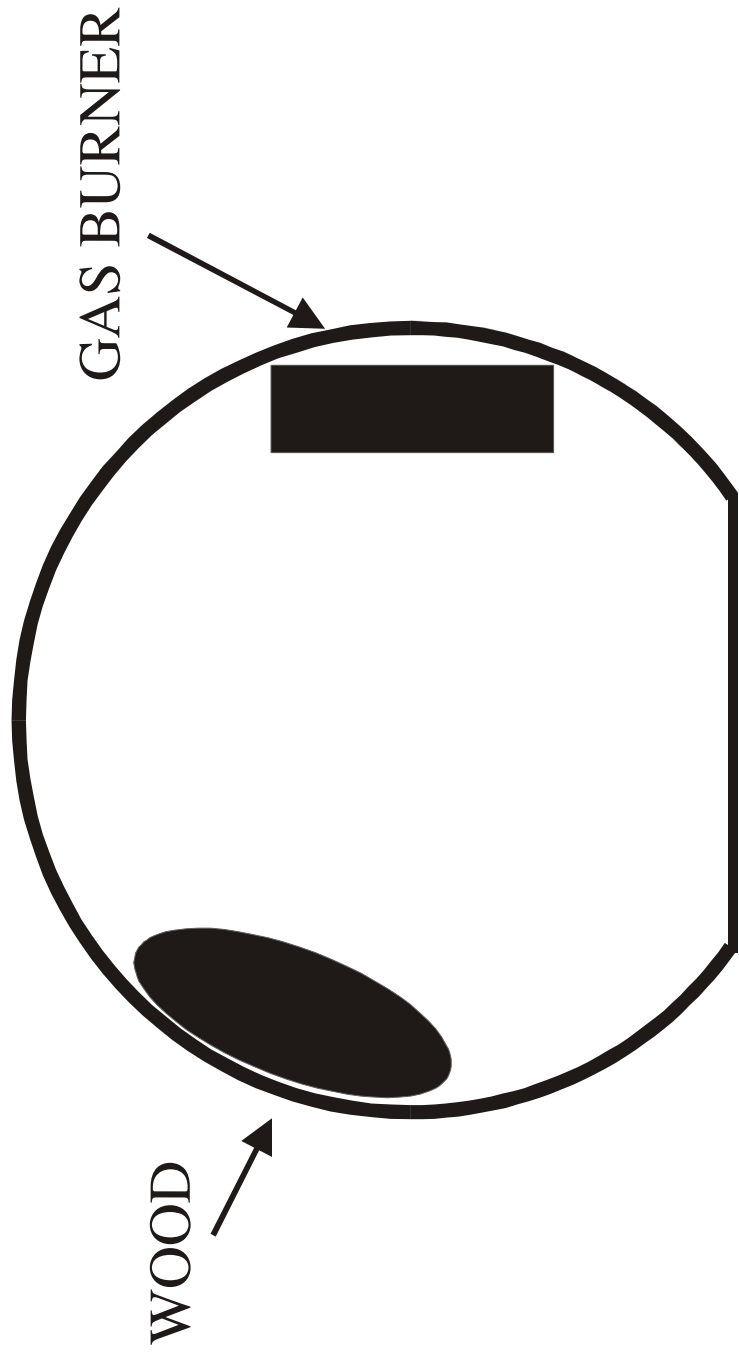

LOG CONFIGURATION

TOP VIEW

#1 LOG HAS A NOTCH TO SUPPORT LOG FROM ROLLING OFF LOWER SUPPORT LOG.

LOG #1

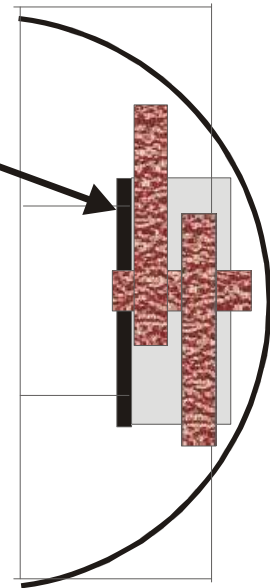

SIDE VIEW

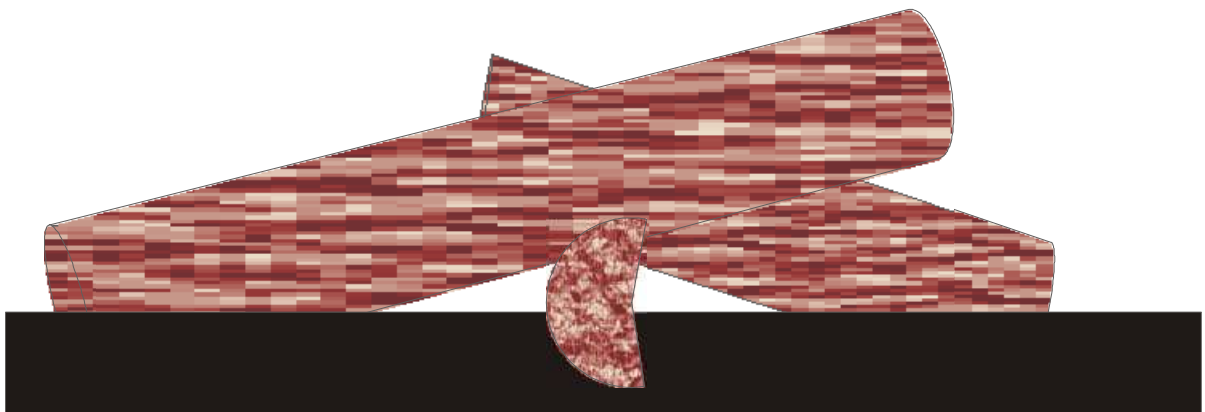

IMPORTANT: PLEASE READ

FOR GAS FIRE OR GAS/WOOD COMBINATION OVENS ONLY

Combustion air intake procedures and installation

Proper installation:

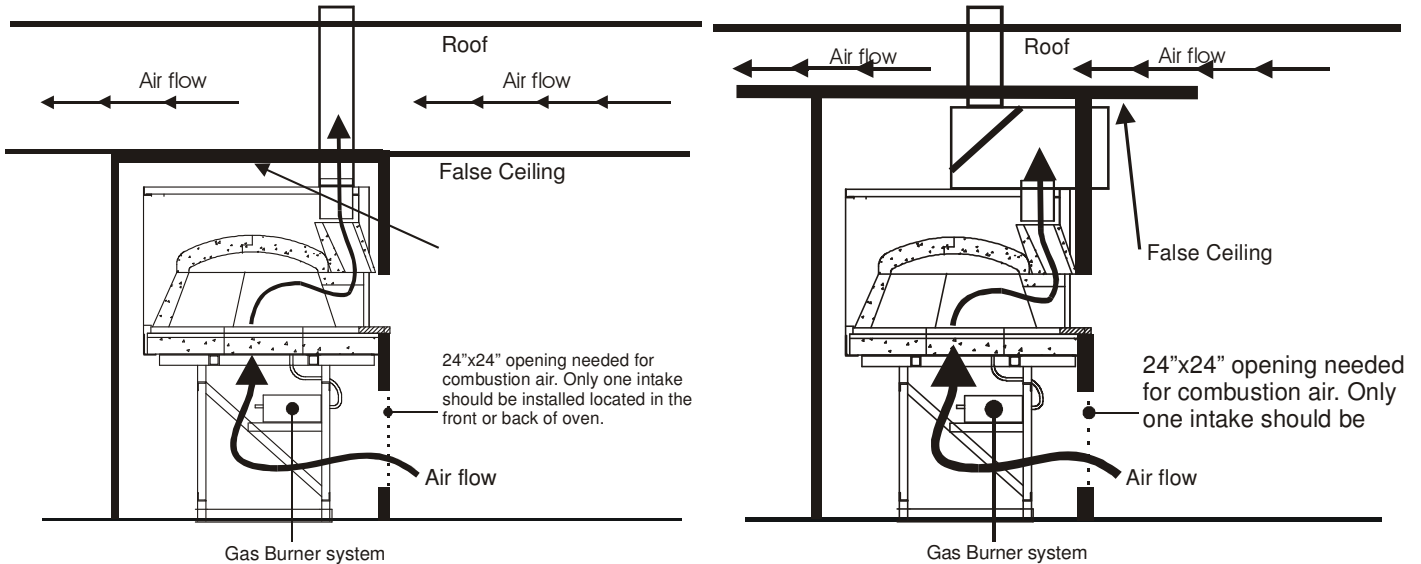

Improper Installation:

1) No air intake opening for burner

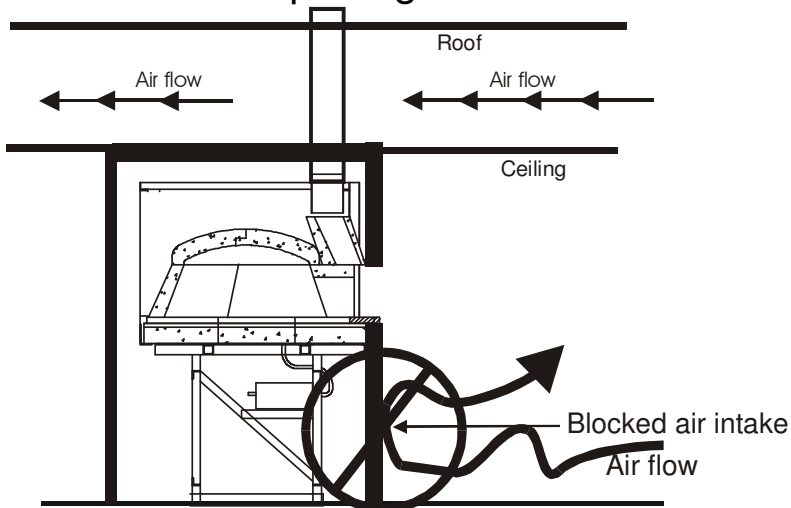

In this case a 24"x24" opening will be needed for proper air combustion.

Improper Installation (cont)

2) Oven is not closed to plenum/attic and is open to HVAC airflow.

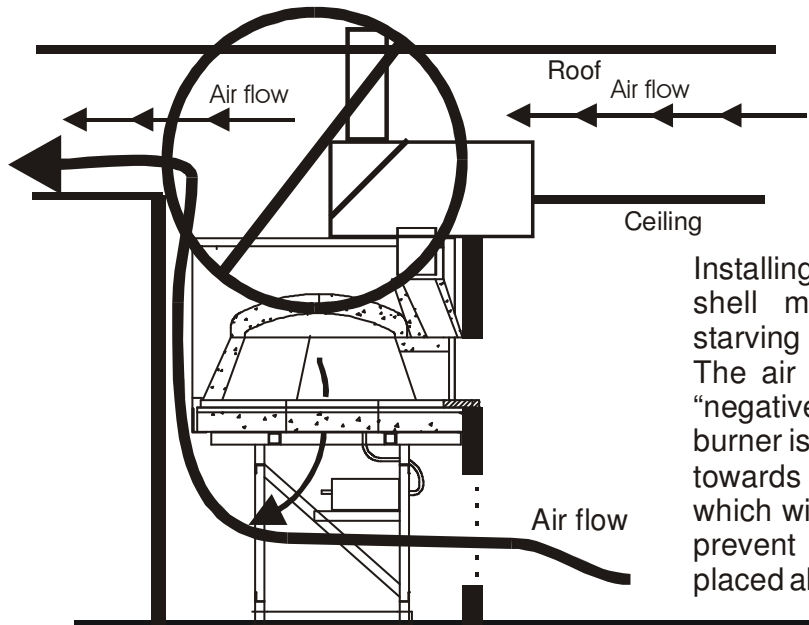

3) Altered air flow from air intake in a separate room with low pressure.

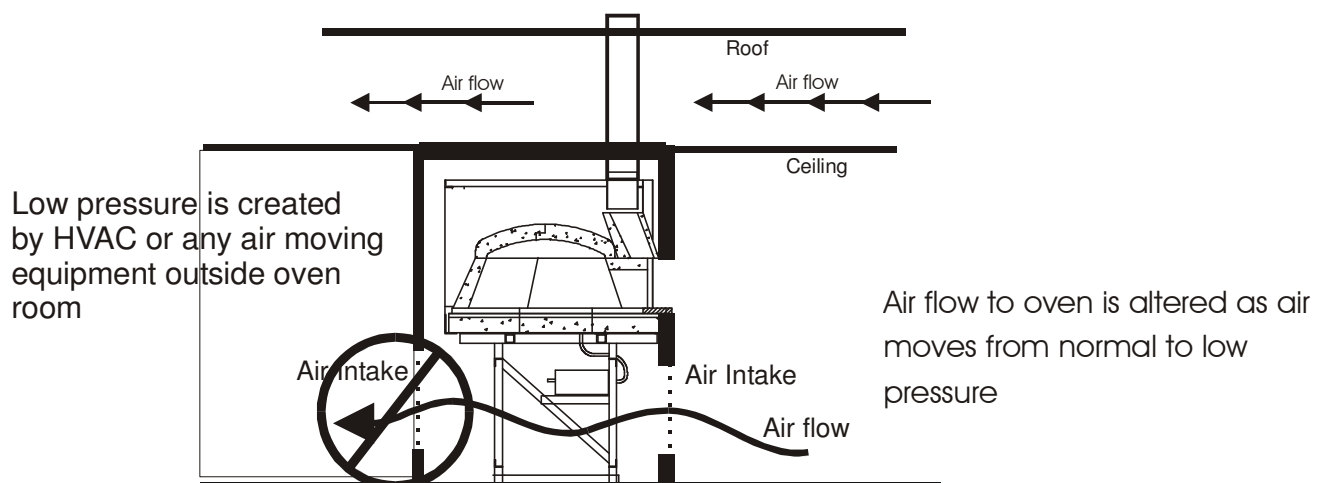

In this case the air intake located on the rear of the oven should be closed.

GAS FIRE START-UP PROCEDURES

- MAKE SURE ALL POWER PLUGS ARE CONNECTED.
- GAS PRESSURE, BEFORE OVEN VALVE, SHOULD BE 7" W.C. FOR NATURAL GAS AND 12" W.C. FOR LP GAS. GAS FIRE MANIFOLD PRESSURE IS SET AT THE FACTORY. PLEASE SEE CHART ON THE BOTTOM OF PAGE 2.
- ADEQUATE CLEARANCE MUST BE PROVIDED FOR AIR OPENINGS INTO THE COMBUSTION CHAMBER, FOR SERVICING AND PROPER OPERATION (PAG AND PAGW MODELS ONLY). **A MINIMUM OPENING OF 24" X 24" MUST BE LOCATED ON THE BOTTOM HALF OF THE OVEN. THIS AREA CANNOT BE BLOCKED**
- CHECK TO SEE THAT MAIN GAS VALVE ON GAS BURNER CONTROLLER BOX IS ON.
- SET TEMPERATURE CONTROLLER TO BELOW 200 DEGREES BY HOLDING DOWN RED BUTTON AND TURNING BLACK KNOB COUNTER CLOCKWISE TO DECREASE AND CLOCKWISE TO INCREASE.
- **REMOVE OVEN DOOR. OVEN DOOR SHOULD NOT BE CLOSED WHEN OVEN IS FIRED. OVEN DOOR CAN BE POSITIONED AT A 45 DEGREE ANGLE TO ALLOW FOR MORE RAPID HEAT UP. WITH A 2 SIDED OVEN YOU CAN HAVE ONE DOOR CLOSED.**
- MOVE HI/LO – HI/OFF SWITCH TO "HI/LO". (UPWARD CLICK)
- TURN ON/OFF SWITCH TO "ON". INITIALLY OVEN MAY NEED TO BE TURNED ON AND OFF 4 OR 5 TIMES (IN 1 SECOND INTERVALS) IN ORDER TO BLEED THE GAS PIPE.

CLICK "ON" WAIT 1 SEC, TURN OFF.

CLICK "ON" WAIT 1 SEC, TURN OFF.

LONGER PIPE LENGTHS MAY REQUIRE MORE BLEEDING.

ALLOW OVEN TO FIRE FOR AT LEAST 5 HOURS AT LOW FLAME FOR 2 DAYS

AFTER 2 DAY FIRING ADJUST TEMPERATURE TO NORMAL OPERATING RANGE 650F-750F

Oven curing is a process of removing moisture from the oven that has accumulated during the oven installation. If you still see moisture from the oven you may need to cure the oven for a few more days. Improper curing may cause small pieces of the oven to pop. Although this is not harmful to the oven in anyway, please follow these procedures.

GAS PRESSURE

Please follow the gas requirements listed below:

Inlet Gas Pressure 7" W.C. for Natural Gas - 12"W.C. for LP gas

Manifold Pressure: The amounts listed below are set at the factory.

Natural Gas Manifold pressure

60-PAGW	4" W.C.	45,000 btu
90-PAGW	4" W.C.	85,000 btu
110-PAGW	5" W.C.	110,000 btu
120-PAGW	3.5" W.C.	130,000 btu
130-PAGW	5" W.C.	140,000 btu
160-PAGW	4.5" W.C.	170,000 btu

Add 0.5" W.C. for ovens with rear burner.

LP Gas Manifold pressure

60-PAGW	7"W.C.	45,000 btu
90-PAGW	10" W.C.	85,000 btu
110-PAGW	10" W.C.	110,000 btu
120-PAGW	10" W.C.	130,000 btu
130-PAGW	10" W.C.	140,000 btu
160-PAGW	10" W.C.	170,000 btu

The inlet and manifold (outlet) pressure taps are located at the Gas Control Valve. This part is in the burner controls box and attached to the oven support stand.

