

MODEL 60-PAG

GAS-FIRED OVEN

The Model 60-PAG gas fired oven has a 23" interior cooking diameter and a 15" wide by 7" high oven entrance. The body parts are a dense cast, high temperature refractory material with an 80% alumina content and additional special additives that stop deterioration from acids emitted by wood combustion. The Model 60-PAG is U.L. listed for installation with a 1-inch side clearance to combustible materials. The small footprint allows for easy installation in tight spaces. . Total weight 1500 lb.

The steel support frame and enclosure are constructed of heavy gauge welded tube steel and angle iron members. All precisely fabricated and attractively designed. The void area between the cast oven body and steel enclosure is entirely filled with a hardened lightweight insulation mixture, which forms a secondary molded body. The combination of our thick cast refractory body and an outer insulation shell maximizes the thermal mass or heat storage capacity of the oven which allows for an extremely efficient oven that cooks at even non fluctuating temperatures.

The temperature probe is placed 2 1/2" into the dome or top of the oven in lieu of on the floor in order to avoid temperature readout fluctuations caused by food items placed on the floor.

Pizza Capacities:

8" Pizzas: 2

12" or 14" Pizzas: 1

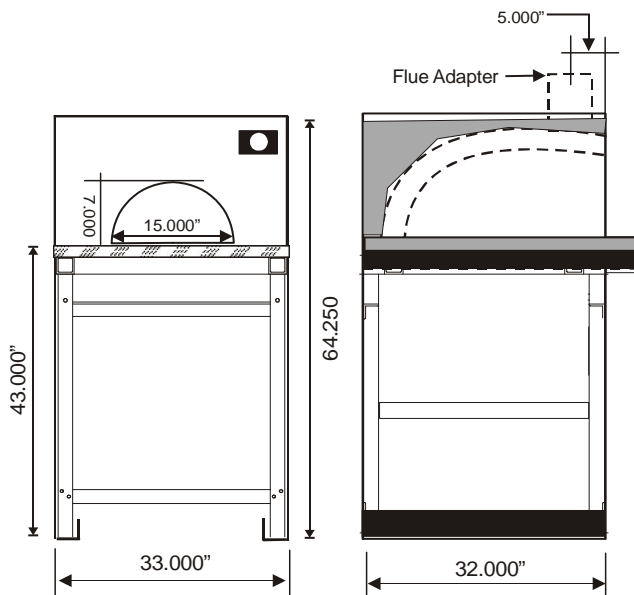

The hearth floor tiles, "Pierre de Boulanger" (Bakers Tiles), which are used in industrial bread baking ovens all across Europe, are refractory material pressed at 8,500 p.s.i. and kiln fired at 2,800 degrees which ceramitizes the material to create a hard and extremely durable tile. Both the body pieces and floor tiles are cast and assembled individually which allows for continuous joints throughout the entire oven. This greatly reduces the possibility of stress cracks due to normal heat expansion and contraction. In addition this allows the ovens to be serviceable which extends their usable life.

Ovens come standard with:

- Factory finished gray paint
- Digital thermometer controller
- S/S Perforated Grate
- Cast Aluminum door with Teflon handles
- S/S Flue adapter
- S/S pizza peel
- 5 year limited warranty

Custom options and finishes available

Gas Requirement: 3/4 inch gas outlet-7" W.C. (LP GAS 10")
BTU's: 40,000

Electrical Requirement: 120 VAC/ 3 AMP

EARTHSTONE

WOOD-FIRE OVENS

6717 San Fernando Rd. Glendale CA 91201

Tel: 800-840-4915 - 818-553-1134 Fax: 818-553-1133

www.earthstoneovens.com



Also in Accordance
With NSFI Standard 4

LA Research Report No. : RR-7813

New York MEA No.: 207-98E

Specifications to change without notice. Revised January 2004