

MODEL 160-PAG

GAS FIRED OVEN

The Model 160-PAG gas oven contains all the same high quality features and components as the Model 160-PA wood fire oven with the addition of a fully automatic gas burner system.

Our heavy duty gas burner system is engineered for optimum performance and long term reliable operation through a straightforward design and the use of high quality components. The solenoid based burner control automatically adjusts flame height and intensity to maintain the preset temperature. All our PAG models are manufactured in Los Angeles.

Interior diameter 64"

Oven entrance opening: 27" wide by 14" high

Clearance to combustible sidewalls: 1 inch

Weight: 6500 lb.

Pizza Capacities:

8" Pizzas: 18-20

12" Pizzas: 12-13

16" Pizzas: 6-7

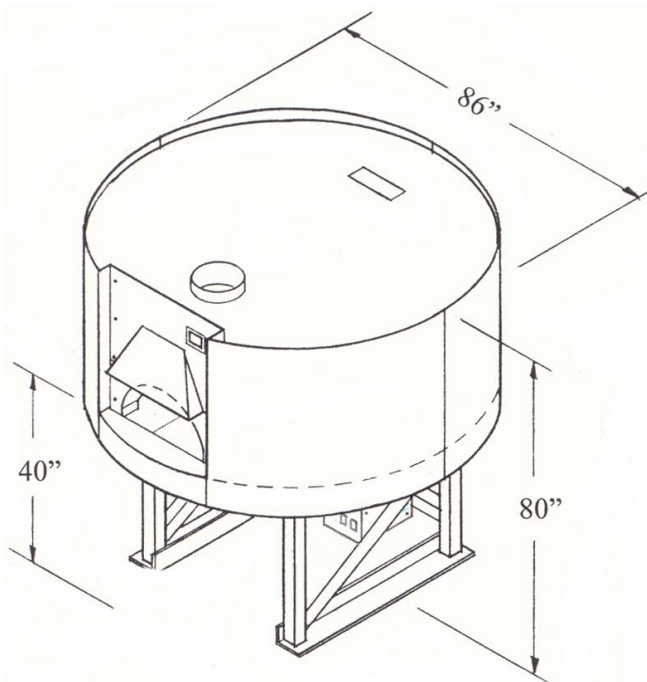

Gas Requirement: ¾ inch gas outlet – 7" W.C. (LP GAS 10")

BTU's: 190,000

Electrical Requirement: 120 VAC/ 3 AMP



Also in Accordance
With NSFI Standard 4

LA Research Report No. : RR-7813

New York MEA No.: 207-98E



Ovens come standard with:

- Factory finished gray paint
- Digital thermometer controller
- Heavy duty gas burner system recessed in floor
- Ceramic fire logs
- Cast Aluminum door with Teflon handles
- Granite shelf
- Hood cover (s/s or copper)
- Shelf apron (s/s or copper)
- S/S Flue adapter
- S/S pizza peel
- 5 year limited warranty

Custom options and finishes available

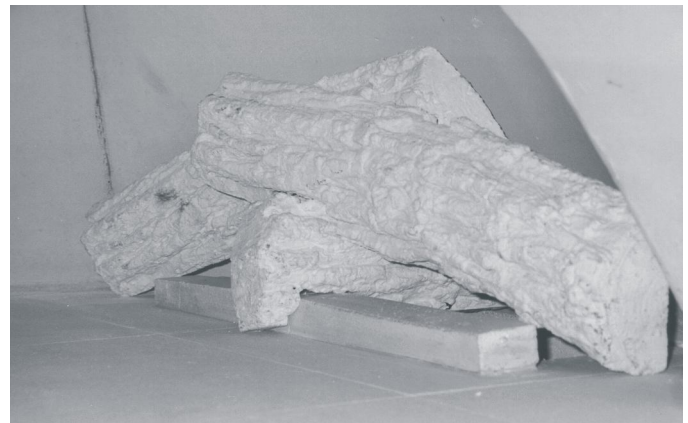

Ceramic fire logs

EARTHSTONE WOOD-FIRE OVENS

6717 San Fernando Rd. Glendale CA 91201

Tel: 800-840-4915 - 818-553-1134 Fax: 818-553-1133

www.earthstoneovens.com

Specifications to change without notice. revised January 2001

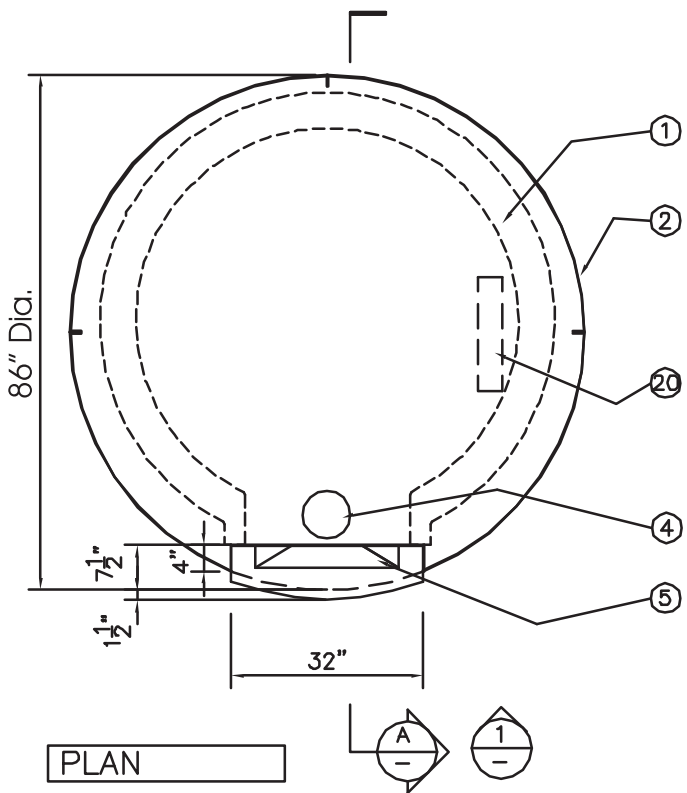

LEGEND

- ① 4"-6" REFRACTORY WALL PIECES
- 2. 16 GA. CURVED STEEL PANELS
- 3. GRANITE SHELF (STANDARD)
- 4. EXHAUST FLUE
- 5. EYEBROW HOOD W/ COVER (S.S. OR BRASS)
- 6. TEMP. CONTROL READOUT PANEL
- 7. FRONT APRON (S.S. OR BRASS)
- 8. 3"x3" STEEL ANGLE
- 9. 2 1/2" STEEL ANGLE BRACING
- 10. 3 1/2" TUBE STEEL
- 11. 5"x3" PERIMETER CURVED STEEL ANGLE
- 12. TEMPERATURE PROBE
- 13. 27 1/2"x14" OVEN ENTRANCE
- 14. OVEN FLOOR TILES (12"x12")
- 15. HARDENED INSULATION FILL
- 16. 1/8" FRONT STEEL PLATES (BLACK)
- 17. 2 1/2" STEEL ANGLE (REMOVEABLE)
- 18. 5"x3" STEEL ANGLE BASE
- 19. STEEL LID W/ 4"x16" SCREEN VENT IN REAR
- 20. GAS BURNER SYSTEM RECESSED IN FLOOR
- 21. GAS BURNER OPERATING SYSTFMS BOX FLEX HOSE AND 72" POWER CORD

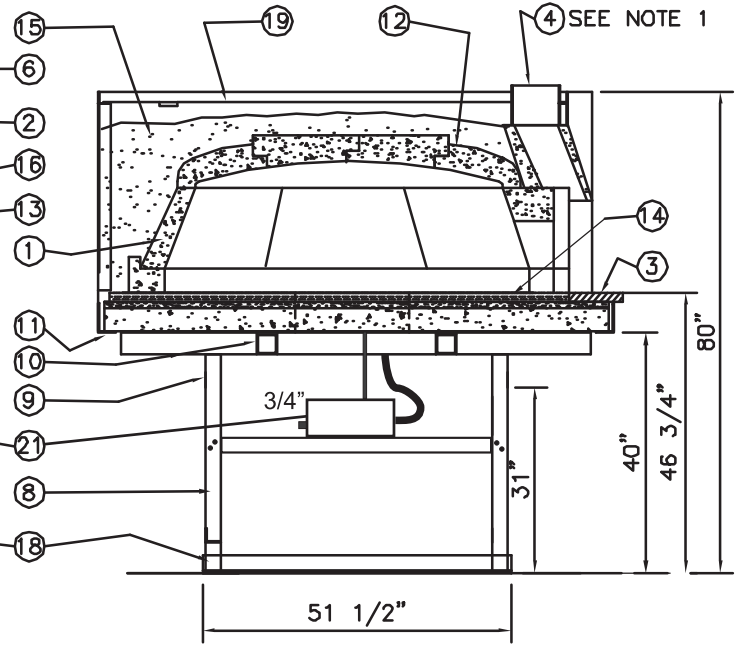
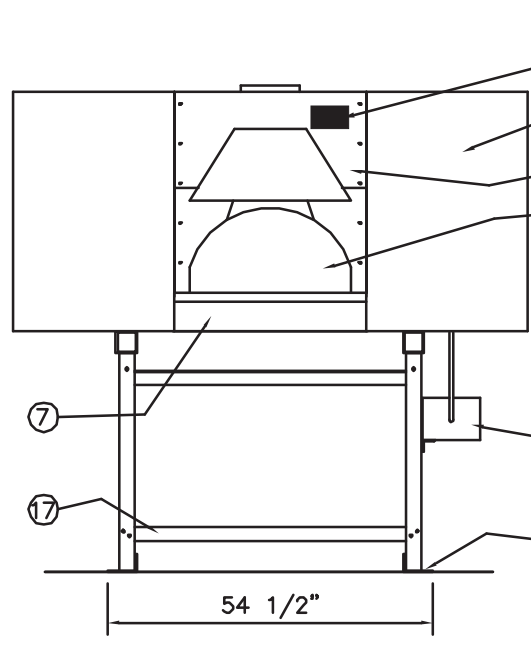

NOTES:

- 1. VENTING APPLICATIONS: USE EITHER A U.L. LISTED GREASE DUCT/BUILDING HEATING APPLIANCE CHIMNEY OR U.L. LISTED TYPE 1 EXHAUST HOOD.
- 2. EXTERIOR SHEEL AND ALL STEEL PARTS ARE FACTORY FINISHED IN GRAY. (OTHER COLOR OPTIONS AVAILABLE).
- 3. GAS REQUIREMENTS: 3/4" GAS OUTLET.
- 4. ELECTRICAL REQUIREMENTS: 120 VOLT AC OUTLET

TOTAL WEIGHT: 6,500 LB
GAS OUTPUT: 190,000 BTU'S

SPECIFICATIONS ARE SUBJECT TO CHANGE WITHOUT NOTICE.

SCALE: 3/8"=1'-0"

EARTHSTONE WOOD-FIRF OVENS	DATE: 10-20-96	TITLE: MODEL 160-PAG GAS FIRED OVEN	SHEET NO. A4
	REVISION: 8-10-2004		